

REVISIONS					
REV.	DATE	ECN #	DESCRIPTION	BY	APP'D

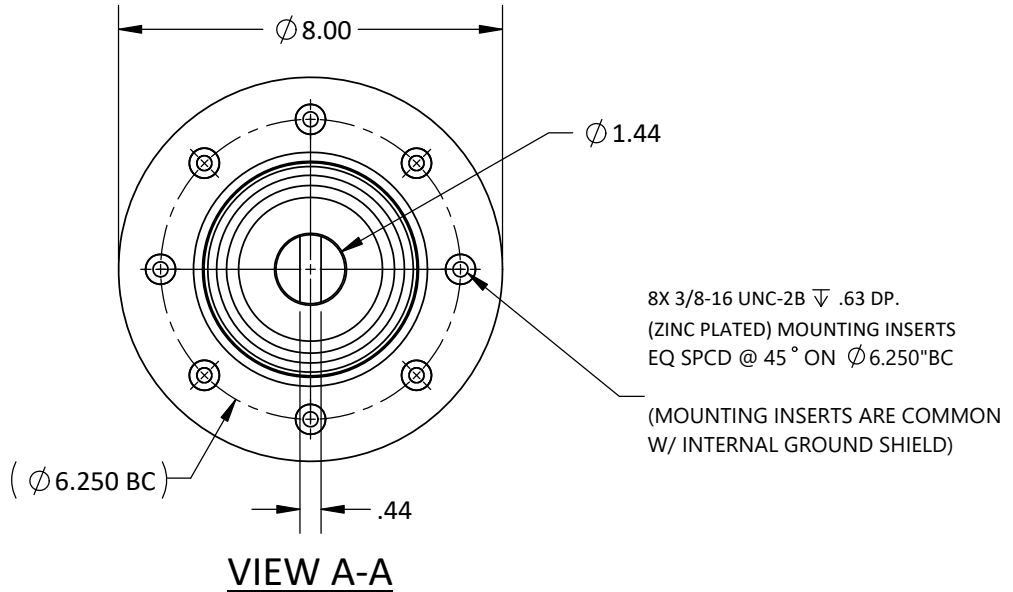
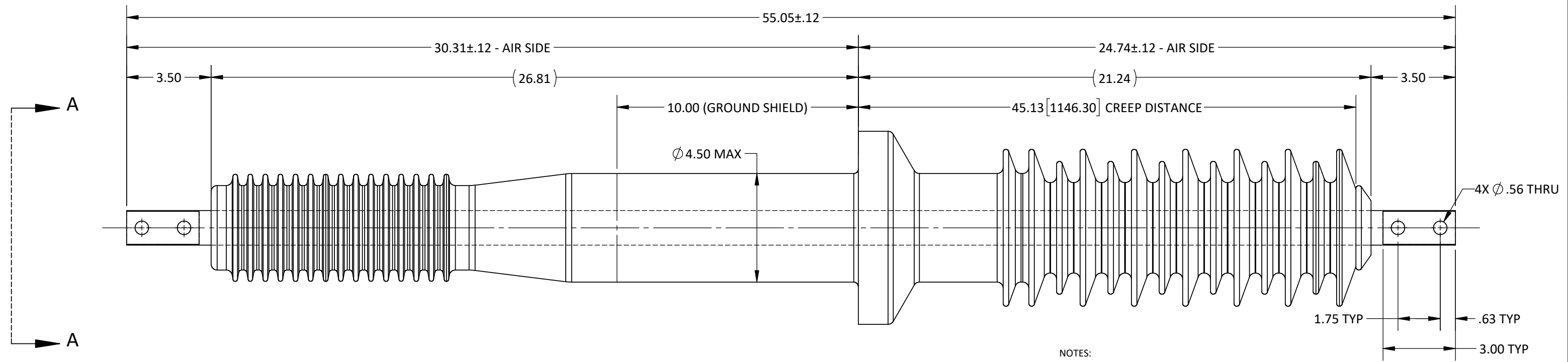

NOTES:
 1. ALL CONTACT SURFACES TO BE CLEAN & FREE FROM FLASH
 2. CANTILEVER LOAD SPECIFICATION, BASED ON (STATIC) LOAD APPLIED HORIZONTALLY AT CENTER POINT OF TOP STUD.

MATERIAL:
 1. CYCLOALIPHATIC EPOXY, GRAY (U.V. EXPOSED)
 2. HD ETP C11000 COPPER, TIN PLATED

SPECIFICATIONS:
 1. MANUFACTURED IN ACCORDANCE WITH.....CAN/CSA-C88.1-96 / ANSI C57.19.01-1991
 2. RATED VOLTAGE.....46kV
 3. POWER FREQUENCY WITHSTAND.....80kV
 4. BASIC IMPULSE LEVEL.....200kV INTERNAL/250kV EXTERNAL
 5. NOMINAL CURRENT RATING.....1200 AMPS
 6. CREEP DISTANCE.....45.13" (1146mm)
 7. TEMPERATURE CLASSIFICATION.....-50 °C TO +105 °C
 8. CANTILEVER LOAD (ULTIMATE).....400 lbf (1760N)
 9. APPROXIMATE SHIPPING WEIGHT.....63.2 lbs (28.7Kg)

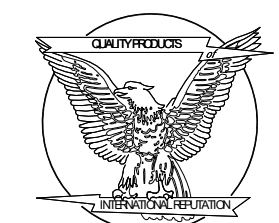
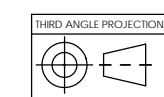

H-J INTERNATIONAL, INC.
 3010 HIGH RIDGE BLVD, HIGH RIDGE, MO. 63049 USA
 PHONE 1-636-677-3421 FAX 1-636-376-1915

46kV / 1200A
 POWER APPARATUS BUSHING

PROPRIETARY AND CONFIDENTIAL
 THE INFORMATION CONTAINED IN THIS DRAWING IS THE SOLE PROPERTY OF H-J INTERNATIONAL, INC. ANY REPRODUCTION IN PART OR AS A WHOLE WITHOUT THE WRITTEN PERMISSION OF H-J INTERNATIONAL, INC. IS STRICTLY PROHIBITED.

TOLERANCES (EXCEPT AS NOTED)	
ONE PLACE MM	±1.50
TWO PLACE MM	±0.75
TWO PLACE DEC.	±.060
THREE PLACE DEC.	±.030
FRACTIONS	± 1/16"
ANGLES	2°

APPROVED BY	DATE
CHECKED BY CJT	DATE 11/30/18
DRAWN BY MAD	DATE 11/30/2018
TOOL NO.	T20-600-1
PRODUCT GRP.	2000 SERIES

DRAWING NO. 20-600-101			
SCALE 1:4	SIZE B	REV. 1	SHEET 1 OF 1

BREAK ALL SHARPS UNLESS OTHERWISE NOTED